

Modulated Infrared Reflective Detector - #3-337

Section 1 - Introduction

This kit detects objects by means of a modulated (flashing) beam of infrared light. Its output signal can sink up to 100 mA for direct drive of an LED indicator, a relay, or as an input to a microprocessor. It makes an ideal proximity detector for miniature robots. Use it wherever you require non-contact object detection at close range with high noise immunity!

Size: 18 x 21 x 9 mm thick (0.75 x 0.88 x 0.38 in.)

Weight: less than 3.4 grams

Voltage: 5.0 V nominal input

Output: open collector, sinks up to 100 mA

Range: to 8 cm (3 in.) depends on target reflectivity

High Noise Immunity: modulated beam reduces response to ambient infrared signals

Easily assembled in under an hour - soldering required. Electronics experience helpful but not required.

In addition, assembly and operation will require:

1. Fine tip soldering iron for electronics
2. Solder for electronics
3. Moist sponge to clean soldering iron tip
4. Wire stripper
5. Side cutter
6. 5 Volt DC power source

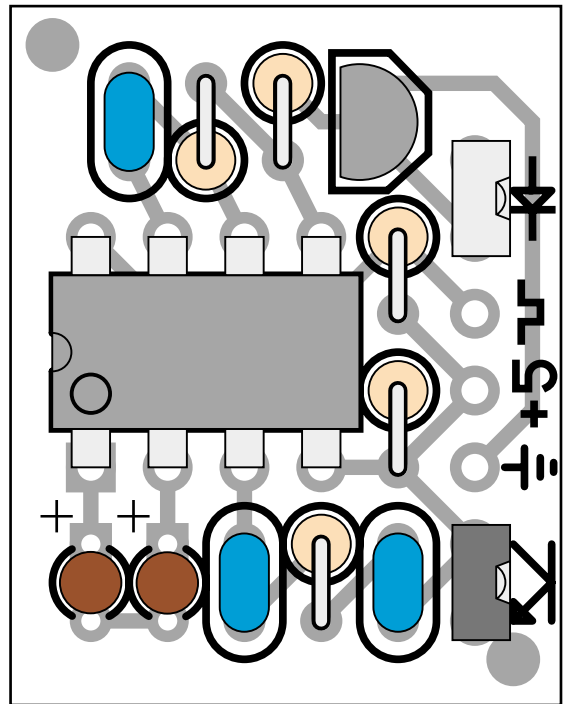

Top view with components in place (enlarged)

Section 2 - Parts List

<u>Item</u>	<u>Quan</u>	<u>Location</u>	<u>Description</u>
1.	1	-	PCB, Modulated IR Detector, Rev -
2.	1	U1*	IC LM567 Tone Decoder phase lock loop
3.	3	C1, 4, 5	Capacitor 0.1 μ F "104" 50v ceramic
4.	1	C2*	Capacitor 0.47 μ F 35v tantalum
5.	1	C3*	Capacitor 1.0 μ F 16v tantalum
6.	3	R1, 3, 5	Resistor 10K Ω 1/8w 5% (brn blk org gld)
7.	1	R2	Resistor 22K Ω 1/4w 5% (red red org gld)
8.	1	R4	Resistor 100 Ω 1/4w 5% (brn blk brn gld)
9.	1	Q1*	Transistor PN2222A NPN general purpose
10.	1	Q2*	IR Detector, side looking, 880nm <-- WAIT TO INSTALL**
11.	1	I1*	IR LED, side looking, 940nm <-- WAIT TO INSTALL**
12.	1	-	Header, Male 0.100" (1 x 7) - optional part
13.	1	-	Instructions, Modulated IR Detector (these!)

* Note proper orientation of part upon installation.

** See "Section 3 - Connection" below for emitter and detector installation options.

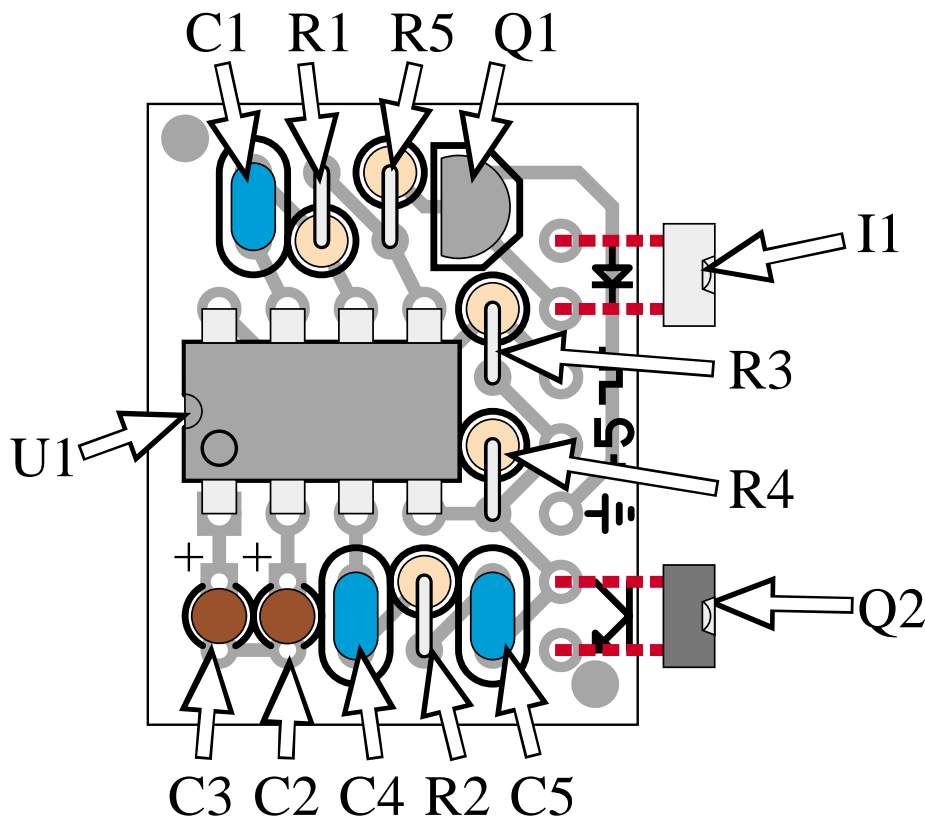

If you have not soldered or assembled electronics before, please see our PDF "How To Solder" on our web site at <<http://www.MuscleWires.com>>, or get the assistance of an experienced assembler.

Install items in the order listed above. Solder them in place, one at a time, double checking the orientation of each part before soldering. Specifically, note the position of the dimple on U1, the "+" leads on C2 and C3, and the direction of Q1, Q2 and I1.

When the solder has cooled, trim off excess lead. Use care as the tiny spacing and holes can be easily bridged by stray solder. Keep it all neat and clean.

Section 3 - Connection

What we cannot see with our eyes, is the entire case of the emitter glowing in infrared when it emits. Furthermore, the phototransistor can pickup enough IR light through the sides or top to detect the signal. Therefore, we must shield carefully against unwanted "direct" infrared light.

- 1) The infra red emitter and detector may be soldered directly to the board with the pair facing off the edge of the board. Wrap the detector in a small amount of shrink tubing or black electrical tape.
- 2) The infra red emitter and detector may be connected to the board by two pair of twisted wires, up to 30 cm (12 inches) long. They can be positioned to detect as needed, again shield the sensor using black tape or shrink tubing.
- 3) A more elaborate sensor can be made by wrapping the emitter and detector individually in aluminum foil, and super-gluing them together, back to back. Then, cut away any foil that might contact the leads of the parts, and sand the *top* surfaces of the pair, and attach to the PC board using long, thin wires (with proper connections, of course). This will detect objects as close as 5 mm (1/4 inch) using only the light emitted from the top of the case!
- 4) The emitter and detector can be extended using small diameter fiber optic light guides (plastic or glass). Epoxy them carefully to the emitter and detector cases, then enclose them with shrink tubing. Use care when shrinking, as the heat can also melt plastic fibers! This can give you a very sensitive detector for very close and precise sensing.

Section 4 - Testing

Attach the board to a 5 Volt DC power supply, and use a volt meter (or an LED with a 1K ohm resistor) to detect the output signal. When the circuit detects its own emitted modulated IR light, the output signal goes low (to 0 volts or so).

Mount a small target (a white hole from a hole punch works well) to a thin wire with a bit of glue or tape. Move the target towards the emitter and detector pair until detected. As you move it around you can map the zone of detection. Try to map out the three-dimensional detection corridor. This information will help you to get the best performance in your application.

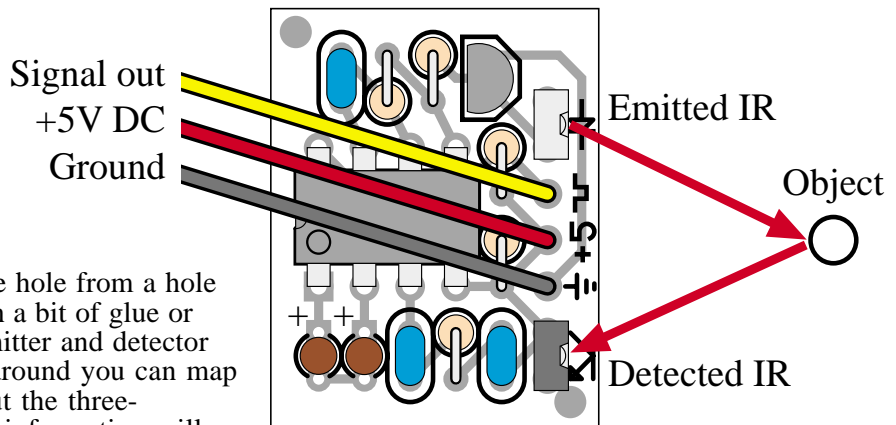

ADJUSTING

You can adjust the sensitivity of the detector by changing the size of the aperture for the detector. (Generally, leave the emitter fully exposed.) A piece of black tape, aluminum foil, or even carefully applied black paint can regulate how much light enters the detector, and from what directions.

You may use several of these boards together, and operate them on different frequencies so that they do not interfere with each other. Simply changing the value of Resistor R1 across the range of 2.2K Ω to 18K Ω will give a modulation frequency from 4.29 KHz to 0.54 KHz, respectively. Steps as small as 1K Ω are sufficient to keep the signals separate, so you can use many of them together in one location, but the different frequencies will not interfere with each other.

Section 5 - How It Works

This circuit uses a matched infrared emitter and detector pair. The emitter LED pulses at a frequency set by the voltage controlled oscillator section of the LM567 Tone Decoder IC. Resistor R1 and capacitor C1 combine to set the center frequency of the VCO to about 909 Hz in this circuit. For other frequencies, see the note in "Adjusting", above.

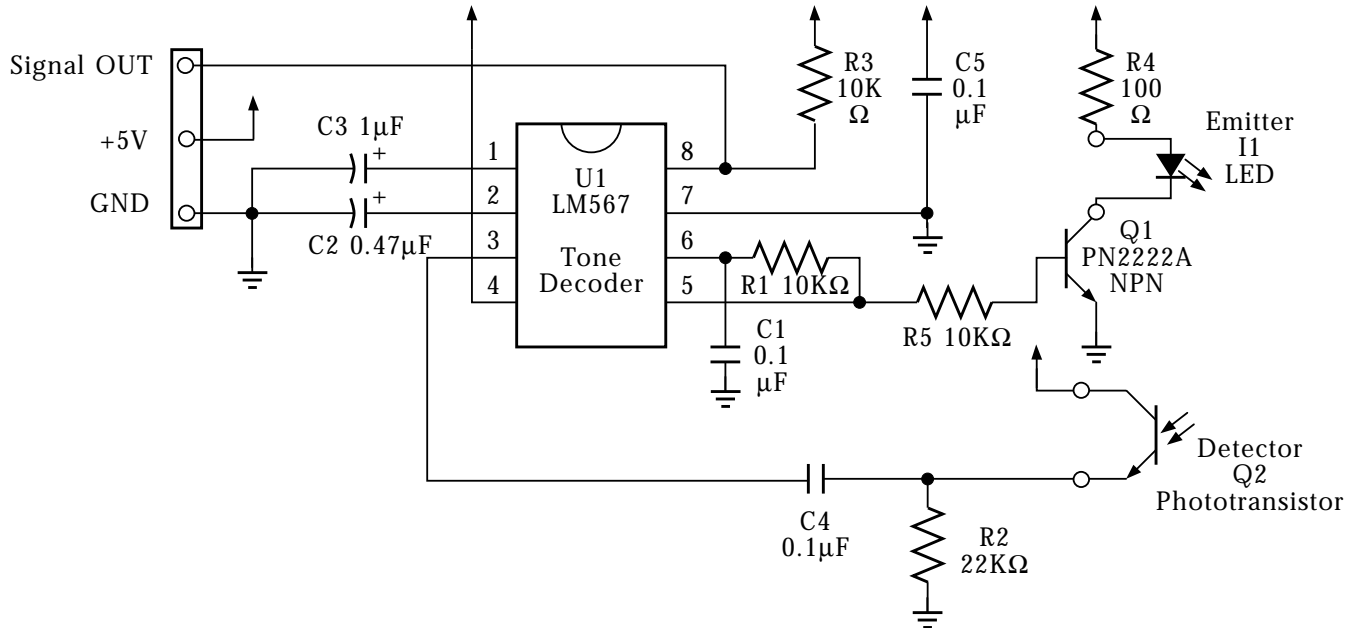

The response to detecting the reflected light from the emitter generates a signal for the tone decoder IC. The decoder compares the input frequency to the frequency it is generating. If the frequency is close enough, then it sends pin 8 to LOW (ground). Otherwise, R3, the 10K Ω pull-up resistor, holds it to 5 Volts. Pin 8 is an open collector output capable of sinking up to 100 mA. For higher currents, add an amplifying transistor, as needed.

For more of the heavy details about the amazing LM567 integrated circuit, refer to the technical documents for this chip, available from many on-line sources.

Contacting Us:

Mondo-tronics, Inc.
 4460 Redwood Hwy #16-307
 San Rafael, CA 94903
 USA

Phone 415-491-4600
 Fax 415-962-4039
 Email mondotronics@email.com
 Web Mondotronics.com

Comments? Errors? Improvements? Compliments?

Help us make this product better with your feedback.

We want to hear from you!