

# Control architectures, design and implementation for 1-DoF haptic interfaces



**KTH Industrial Engineering  
and Management**

**SULEMAN KHAN**

Supervisor: Jan Wikander

Bengt Eriksson

Department of Machine Design  
Royal Institute of Technology  
SE-100 44 Stockholm, Sweden.

TRITA-MMK 2010:\_22  
ISSN 1400-1179  
ISRN/KTH/MMK/R-10/22-SE

<b>Mechatronics Lab</b> <b>Department of Machine Design</b> <b>Royal Institute of Technology</b> <b>S-100 44 Stockholm</b> <b>SWEDEN</b>		TRITA - MMK 2009: ISSN 1400 -1179 ISRN/KTH/MMK/R-09/-SE	
<i>Author(s)</i> Suleman khan (sulemank@md.kth.se)		<i>Document type</i> Report.	<i>Date</i> 2009-10-09
<i>Title</i> Control architecture , design and implementation for I – DoF haptic devices		<i>Supervisor(s)</i> Jan Wikander, Bengt Erikson  <i>Sponsor(s)</i> Sponsor	
<i>Abstract</i>  <p>This study is a part of the research continued on haptics at Mechatronics Lab, Machine design dept at the Royal Institute of technology - KTH. The purpose of the study was to review different control architecture used for the control of haptic interfaces. In the phase to design and implements the different control strategies on 1-DoF haptic device. To implement the control structures some basic design requirements were considered such stability, stiffness performance of the close loop structures etc. On the basis of these requirements various impedance structures and Admittance structures were implemented and tested on 1-DoF haptic device. Results and conclusion was presents in detail to identify the best control architecture for 6-Dof haptic device. The main goal of this study was to propose and develop a control system for a new 6-DoF haptic device. As the device will be used for stiff contact force and torque feedback therefore the control architecture play important role in the transparency of the device.</p>			
<i>Keywords</i> Keyword1, Keyword2, Keyword3		<i>Language</i> English	

# Table of contents

---

---

TABLE OF CONTENTS.....	2
LIST OF FIGURES .....	2
CONTROL ARCHITECTURE OF HAPTIC INTERFACES.....	3
1 INTRODUCTION .....	3
1.1 DESIGN FACTORS FOR CONTROL OF HAPTIC INTERFACES .....	3
1.2 CONTROL ARCHITECTURE .....	4
1.3 CONCLUSION.....	11
1.4 STABILITY PROBLEM OF HAPTIC INTERFACES .....	12
1.5 DYNAMIC MODEL OF HAPTIC INTERFACE .....	12
1.6 IMPLEMENTATION OF HAPTIC CONTROL STRUCTURE FOR 1-DOF HAPTIC DEVICE. ....	13
• OPEN LOOP IMPEDANCE CONTROL .....	14
• OPEN LOOP IMPEDANCE CONTROL WITH CURRENT FEEDBACK FOR ACTUATOR.....	15
• CLOSE LOOP IMPEDANCE CONTROL WITH FRICTION AND BACK EMF COMPENSATION.....	15
• CLOSE LOOP IMPEDANCE CONTROL WITH FRICTION AND BACK EMF AND USER CONTACT FORCE COMPENSATION .....	16
• COMPENSATION FOR GRAVITY TERM .....	17
• ADMITTANCE CONTROL .....	19
REFERENCES.....	20
CHAPTER 1 PI CONTORLER FOR MOTOR TO CONTROL CURRENT .....	23
CHAPTER 2 PI CONTROLER FOR MOTOR WITH LOW PASS FILTER TO CONTROL CURRENT.....	24

## List of Figures

---

---

FIGURE: 1.1 HAPTIC INTERACTION LOOP WITH USER AND VIRTUAL ENVIRONMENT. MECHATRONICS LAB [KTH UNIVERSITY] .....	3
FIGURE 1.2. HAPTICS AND GRAPHICS RENDERING SYNCHRONIZATION. [9].....	4
FIGURE: 3.3 A) LOOP OF IMPEDANCE CONTROL SYSTEM B) LOOP OF ADMITTANCE CONTROL SYSTEM USED IN HAPTIC DEVICES [6]. ....	5
FIGURE 2.11. HAPTIC RENDERING LOOP THAT REPRESENT THE COLLISION DETECTION AND FORCE FEEDBACK MECHATRONICS LAB [KTH UNIVERSITY].....	<b>ERROR! BOOKMARK NOT DEFINED.</b>

# Control architecture of haptic interfaces

## 1 Introduction

Haptic interface is a mechanical device similar to a robot that enables human interaction with virtual environment or teleoperated system. The haptic feedback interface sense the position and orientation of the user and then provide feedback forces and torques to the user, on the bases of what the user interacts and manipulate in the virtual environment as shown in figure 1.1

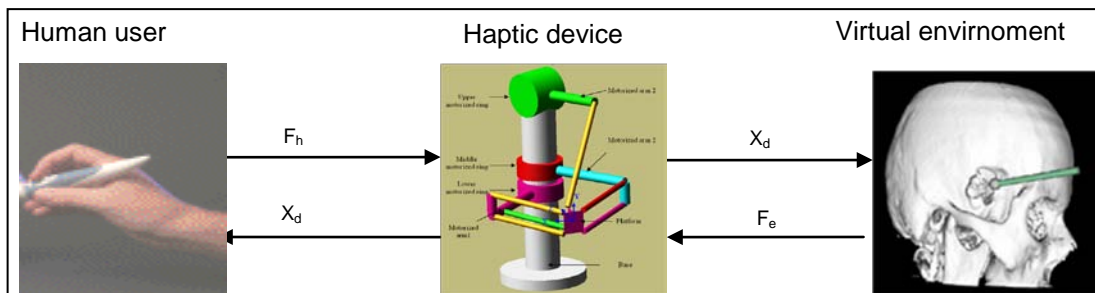

Figure: 1.1 Haptic interaction loop with user and Virtual Environment. Mechatronics Lab [KTH university]

The above diagram shows that the user exerts forces and torques on the end-effector to move it, the haptic interface sense the position of end-effector and send it to the virtual environment to move the virtual styles accordingly. Whenever the virtual styles come in interaction with objects it send feedback forces and torques to the device that the user can feel. If there are no interaction with objects (free motion), which mean no forces from virtual environment and end-effector will follow only the forces from the user hand.

The haptic control and visual computation at virtual environment may be done on different platforms, depending on their system architecture. In a typical implementation, the haptic interface requires high update rates around 1000 Hz to ensure stability and responsive interface. While the visual interface (virtual environment) typically updated at low rate around 30-60 Hz [2]. The high update rates needed for haptic rendering requires the graphic and haptic rendering to be separated into concurrent threads of execution, as shown in Figure 1.2. The application processing and graphics rendering is typically performed in the same thread. Haptic rendering is performed in a separate dedicated thread. Since the user can see and feel the virtual environment simultaneously, it is critical that haptic and graphics rendering threads be synchronized. Failure to synchronize the two threads can cause a disparity in what the user sees and feels in the virtual environment.

### 1.1 Design factors for control of haptic interfaces

A haptic interface presents a difficult design problem, as it is required to provide enough *stiffness* as well as be *light* and *backdrivable* (the ability to move the end-effector in the workspace and the user feels no resistance or opposition (from interface) in case of free motion). Also *Structural transparency* is required so that the user should feel actual forces from the virtual environment not that of the structure of the haptic interface. These basic requirements imply that following design criteria should be followed while designing a haptic control system.

- i. Free space must feel free

- ii. solid virtual objects must feel stiff
- iii. Virtual constraints must not be easily saturated- (actuators must provide enough forces to feels solid objects).

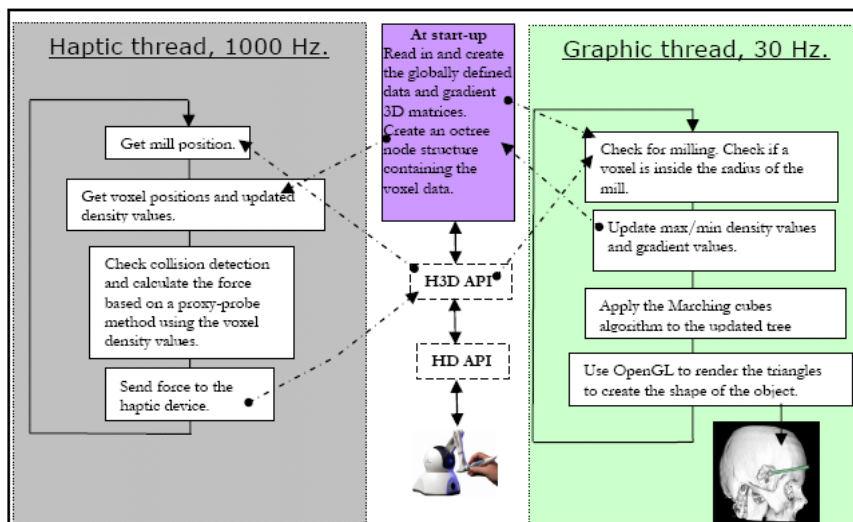

Figure 1.2. Haptics and graphics rendering synchronization. [2]

It is important that the natural dynamics of the haptic interface must not distract the user from the environment being simulated. This implies that the interface should have the lowest possible inertia; friction and no backlash in order to increase the transparency of the device and don't produce extra forces (dynamics of the haptic device). Secondly the device must be capable of producing a stiffness, enough to believe that contact within virtual environment has taken place. The minimum stiffness usually taken is 20 N/cm in order to feel rigid bodies contact in virtual environment [1]. Also the device should produce enough force so that virtual objects feel solid or rigid [1], to avoid the actuators saturation.

The first criterion can be satisfied either through passive design or active control. The stiffness requirement is fulfilled by making the mechanism stiff and using a high bandwidth controller. The third one requires that the control law be computed at a very fast rate. The saturation requirement is a function of the actuator output peak forces. The higher the force produced at the haptic interface, the larger the forces that must be supplied by the actuators.

## 1.2 Control architecture

Haptic interfaces belong to the family of mechatronics devices. Their fundamental function is to take advantage of mechanical signals to provide and control communication between user and virtual environment. There are two major ways in which a haptic device can be controlled; impedance control and admittance control system [6].

**Impedance control system** In impedance control system, the device sense motion (position and orientation) input by the user and control the forces applied by the haptic device. The basic interaction loop between user and control system is "displacement in - force out". A prime example of the impedance control system is Sensable's well known series of PHANTOM devices [1].

**Admittance control system** In admittance control system, the device sense forces commanded by the user and control the motion (velocity or position) of the device. The

basic interaction loop between user and control system is "force in - displacement out". A prime example of the Admittance control system is FCS Haptic Master [3].

**Hybrid control system** Sometime force is used as an additional input to the impedance controller or displacement is used as an additional input to the admittance controller. In this case, the type of output (force or position) will be used to determine the class of control system, usually called hybrid control system. A prime example of the Hybrid control system is ViSHARD6 serial haptic devices [4].

Type of control used depends on the application being considered. Impedance control interface are by nature lightly built and highly backdrivable [3]. They are generally used when the environment being simulated was highly compliant such as human tissue in surgical simulators. There is a limit to the hardness or stiffness of a virtual object that can be rendered stably with impedance control system [3]. Any small changes in position will cause a very high rise in actuator reaction force while the device is in contact with stiff virtual object. This implies a very high control gain from measured device position to actuator force. And for stability, control gains cannot become infinity high. On the other hand admittance control was used to manipulate rigid constraints (simulated contact with stiff and heavy objects). These systems are highly geared and therefore non-backdrivable and provide high forces at the end-effectors. Research is continuing on adaptive and robust haptic control [9] that will help to improve the performance of the haptic devices. For high level of performance, admittance display must be actively masked inertia and damping. The commonly adopted control systems for haptic device are presented below in detail.

#### ❖ Open-loop impedance control

Simple control architecture of the haptic device with small inertia is open-loop impedance control system. Block diagram of a typical haptic controller is shown in figure 1.3

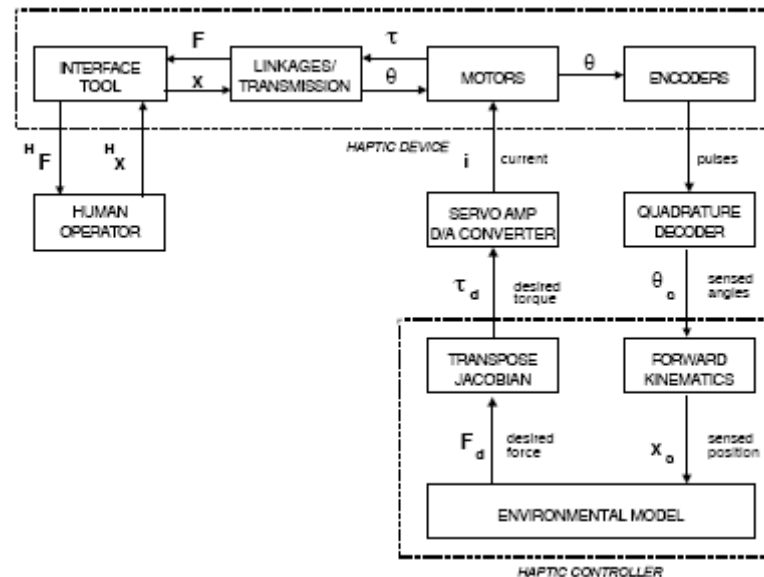

Figure: 1.3 Open-Loop Impedance control of PHANTOM™[1]

When the user moves the end-effector, encoders mounted on the motors shafts read the joint angles. Using the forward kinematics these angles are mapped to find the position of the end-effector  $X_s$ . The virtual environmental model uses this position to update the virtual styles and then calculate the desired forces  $F_d$  based on interaction with objects. The desired force response is mapped to a set of torques using a Jacobian matrix; these are the torques to be produced by the motors in the haptic device. Then the manipulated forces are

transmitted to the end-effector through linkages, which the user can feel. The range of force is determined by the close loop impedance. A close loop impedance represents the relationship of output force to input position in the transfer function (Laplace transform). Strictly speaking, the impedance is the relationship between velocity and force not position [1].

$$Z = \frac{F}{V}$$

To design the controller, the desired (close loop) impedance is specified for any given environment which represents the contact characteristics [5]. That is, the contact impedance between the haptic interface, human user and virtual environment. It can be maintained as desired by adjusting the impedance of the haptic interface. The impedance model of the haptic interface ( $Z_m$ ) is a controller that determines the relation between the force and the velocity of interface, or represents the linear dynamic model of the haptic interface. It is important to note that the user affects the impedance of the control loop. A contact model between the user and the haptic interface ( $Z_u$ ) is necessary for defining the desired characteristics of the contact force. The dynamic model of the user ( $Z_u$ ) can be represented by first order differential equations as [5]

$$F_u = b\dot{x} + kx \quad \text{or} \quad Z_u(s) = \frac{F_u(s)}{V(s)} = b + \frac{k}{s}$$

Where b and k represents the operator's damping and stiffness coefficients, respectively and s represent the Laplace domain.

A continuous model of the whole system is shown in figure 1.4 [6][8][9]

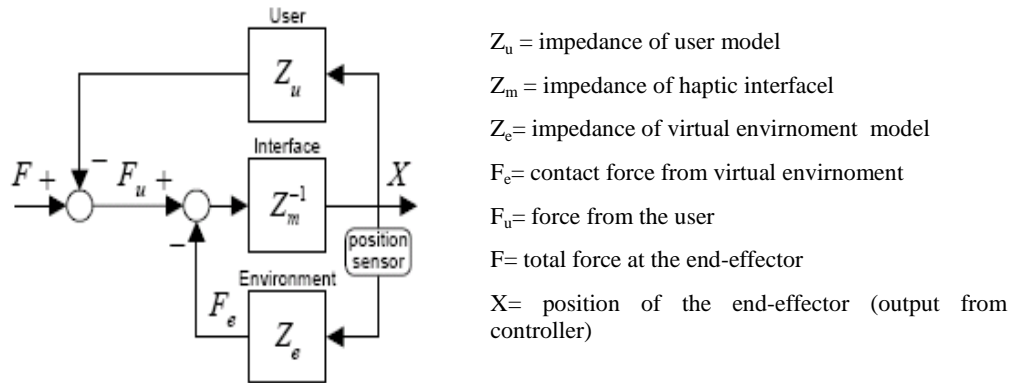

Figure: 1.4 Impedance interaction model of haptic device [6]

The block diagram in above figure can be used to determine close- loop impedance achieved at the haptic interface.

$$X = Z_m^{-1}(F - F_u - F_e)$$

$$F_e = Z_e X \quad \text{and} \quad F_u = Z_u X$$

Now substituting the value of  $F_e$  and  $F_u$  in above equation will result

$$X = Z_m^{-1}(F - Z_u X - Z_e X)$$

$$(Z_u + Z_e + Z_m)X = F$$

$$\frac{X}{F} = \frac{1}{Z_u + Z_m + Z_e}$$

The above equation represents that the total impedance is the sum of the dynamics of the users arm, haptic interface and virtual environment. The controllability of the impedance within the workspace is important factor in the design. This mean that during the free motion the user should be able to feel free (no contact force from environment) and during the contacts the user should be able to feel the same forces. In order to achieve this, the dynamics of the haptic device should be compensated for.

However this control system causes a stability problem to simulate a high inertia and stiff environment, due to the saturation of actuators, resonant modes of the haptic device and sampling of the position signal etc.

### ❖ Impedance control with feed-forward term

One solution to the above described problem is to include the feed-forward term, to the control law in figure (1.4) as used by Hogan [7]. The main goal of the feed-forward term is to cancel out or reduce the corresponding inertial terms in the dynamics of the haptic interface as shown in figure 1.5a.

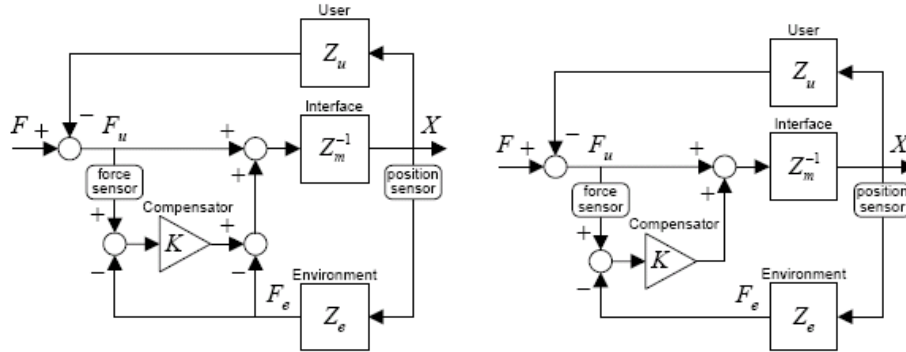

Figure: 1.5 a Impedance model with feed-forward b) force feed-forward

The block diagram in above figure can be used to determine close- loop impedance achieved at the haptic interface as.

$$X = Z_m^{-1}(F - F_u + K(F_u - F_e))$$

$$F_e = Z_e X, F_u = Z_u X \text{ and } F_m = KF_u - (1 + K)Z_e X$$

Now substituting the value of  $F_e$  and  $F_u$  in above equation will result

$$\frac{X}{F} = \frac{1}{Z_u + \frac{Z_m}{1 + K} + Z_e}$$

Another version of this architecture is shown in figure 1.5b, it is called force feed-forward impedance control. The final equivalent close-loop impedance is

$$F_m = K(F_u - Z_e X)$$

$$\frac{X(s)}{F(s)} = \frac{1}{Z_u + \frac{Z_m}{1 + K} + \frac{K}{1 + K}Z_e}$$

In this architecture the inertia of the system is reduced by adjusting the gain value  $K$  as large as possible. However, this can make the system unstable. Also the force sensor causes some stability issues.

### ❖ Impedance control with feed-back term

A different approach to decrease the inertia of the mechanical interface felt by the user is to include a positive motion feedback ( $Z_c$ ) as shown in figure 1.6a. The final impedance with this structure is

$$F_m = Z_c X + Z_e X$$

$$\frac{X(s)}{F(s)} = \frac{1}{Z_u + Z_m + Z_e - Z_c}$$

In order to cancel the dynamics of the haptic device,  $Z_c$  should be equal to  $Z_m$ . Therefore



it is required a good estimated model for stiffness, damping, and inertia of the device . The drawback with this structure is the perfect compensation otherwise the impedance calculated at the output will be incorrect. Also the static friction cannot be compensated using this structure, because no change in force can occur without a change in motion. Amplification of noise signal may be a problem due to the compensator model and will cause a stability problem.

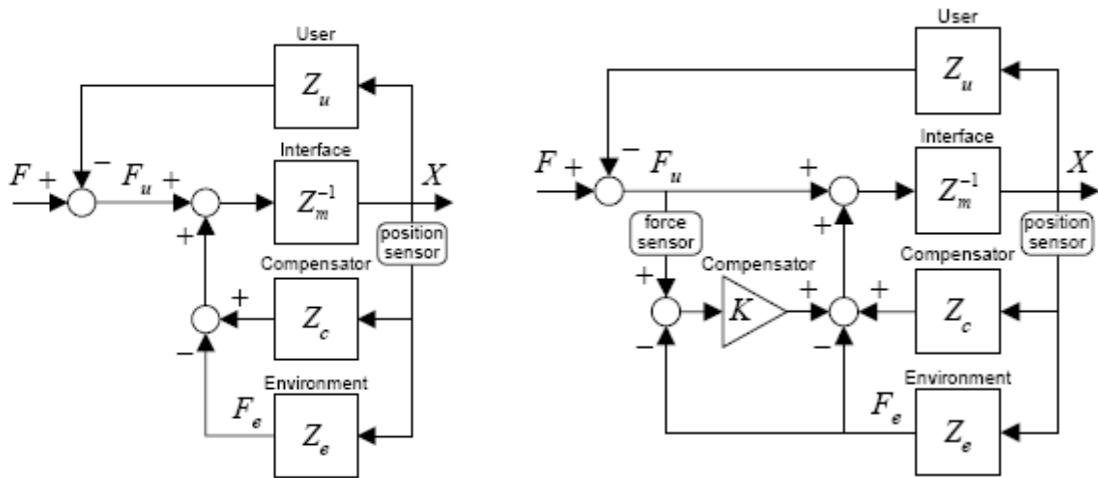

Figure: 1.6 (a Impedance model with motion-feedback b) Hybrid control structure

#### ❖ Impedance control with hybrid compensation

This architecture consists of positive feed-back and feed-forward compensation in the same structure as shown in the figure 1.6b. Therefore the final equivalent impedance includes the benefits of both feed-forward and feedback models: the transfer function of the feedback is subtracting inertia from the mechanical interface and the gain of the force feed-forward is dividing the resulted inertial terms.

$$F_m = KF_u - (1 + K)Z_e X + Z_c X$$

$$\frac{X(s)}{F(s)} = \frac{1}{Z_u + \frac{Z_m - Z_c}{1 + K} + Z_e}$$

The hybrid control architecture was used by M. Buss [11] to control system for ViSHARD 3 haptic device. In this, a model feed-forward is used to compensate for gravity (G) and friction (B) of the device. Where K is the gain of the force feedback controller which has been calculated by a control law as shown in figure [1.7].

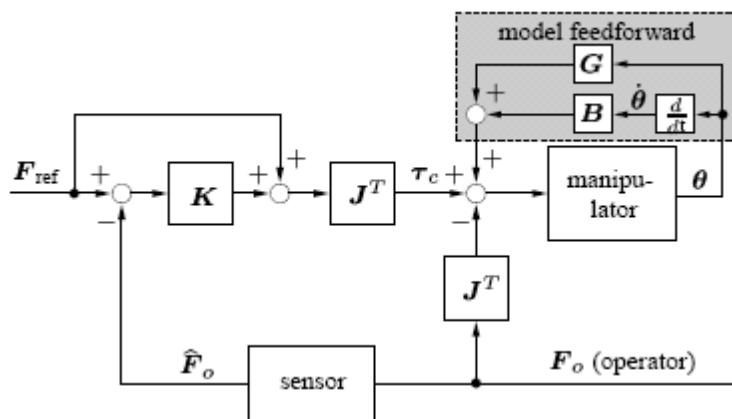

Figure: 1.7 (a Impedance model with force feedback

❖ **admittance control**

As in the admittance control architecture the control law is force in and position out-mean it control the position of the haptic interface. This scheme typically will suit for device with high dynamics and for stiff contacts. The most favour admittance control architecture developed by Maples and Becker [7] called “admittance control with position feedback”. The architecture is shown in figure [1.8]. If there is no virtual contact, the desired dynamics of the envirnoment,  $Z_e$ , is replaced by a desired dynamics in free movements,  $Z_m$ .

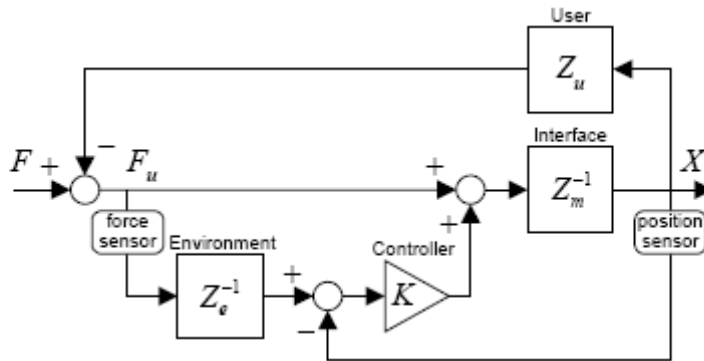

Figure: 1.8 Admittance control structure

The block diagram in above figure can be used to determine close- loop impedance achieved at the haptic interface as.

$$F_m = K(F_u Z_e^{-1} - X)$$

$$\frac{X(s)}{F(s)} = \frac{K + Z_e}{Z_e [Z_u + Z_m] + K [Z_u + Z_e]}$$

In this control law if gain K is sufficiently large compared to  $Z_e$  then the impedance felt by the user is approximately

$$\frac{X(s)}{F(s)} = \frac{1}{[Z_u + Z_e]}$$

The control scheme is implemented for control of HapticMaster [3]. The HapticMaster measures the force exerted by the user, preferably measured close to the human hand with a sensitive force sensor. A virtual model calculates velocity, and acceleration (PVA), sensed force. The PVA-vector is commanded to the robot haptic interface to control the motion through a device control law as shown in figure [1.9]. The virtual model in the figure represents masked inertia, to avoid commanding infinite accelerations. While the control loop will cancel the real mass and friction of the mechanical device, this result backlash-free and smooth moving behavior of the end effector.

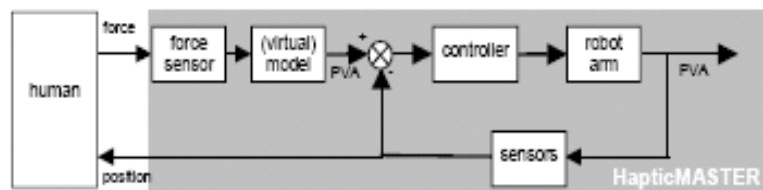

Figure 1.9 the general control scheme of the HapticMaster [3] comprises an outer control loop, and an inner servo loop. A (virtual) model converts the force sensor signal to a

Position/Velocity/Acceleration setpoint vector. The inner servo loop controls the robot to the PVA setpoint values.

The Cobic haptic display is another example that use the admittance control [13]. Here the force  $f_1$  is directly applied to the virtual tool. The acceleration of the virtual tool is then calculated via Euler-Lagrange equations and integrated forward. The acceleration is transformed by the kinematics to an acceleration of the end-effector. This acceleration is a feed-forward term applied to the reference end-effector. In addition to this feed-forward acceleration, feed-back acceleration is applied to compensate for small position and velocity errors between the end-effector and the reference. The result is a realistic display of the constrained dynamics of the virtual tool. A block diagram of the admittance-type haptic control scheme described here is shown in Figure 1.10.

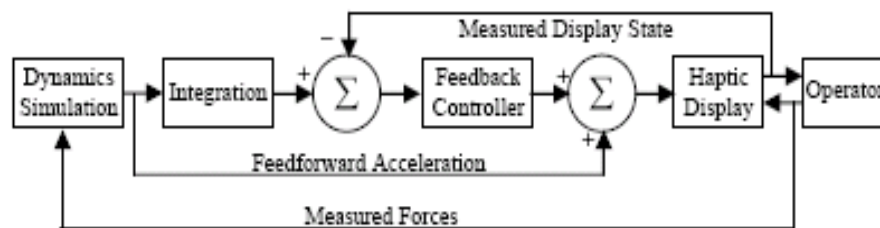

Figure 1.10 The admittance-controller used in Cobic haptic display [13]. Measured forces are the input to a dynamics simulation of a virtual environment. The output of the dynamics simulation yields a feed-forward acceleration, and state for comparison with the measured state of the haptic display via a feedback controller.

#### ❖ Adaptive control

Adaptive controls typically used in uncertain environmental or external conditions. It involves modifying the control law to handle with the fact that the system has uncertain parameters that vary over time. The general control scheme of adaptive control architecture is shown in figure 1.11. Here in adjustment block make the modification to control law according to the change in parameters over time.

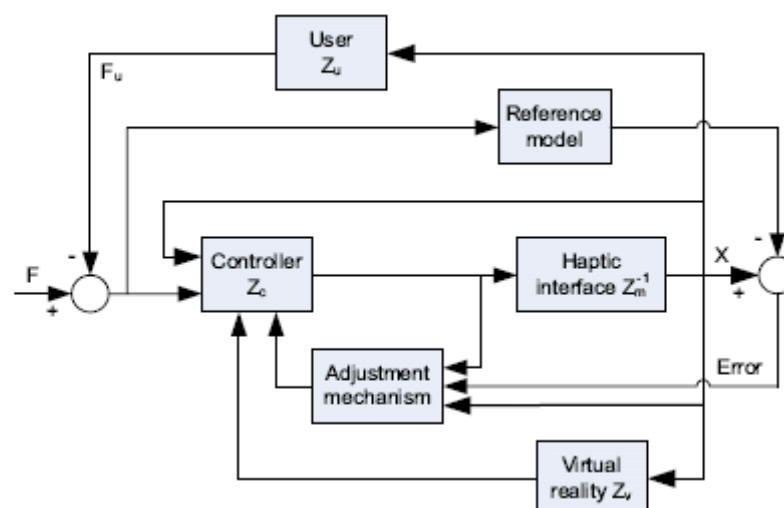

Figure 1.11 Adaptive control scheme [8].

### ❖ Robust control

A robust controller is able to cope with the differences between a real system and the dynamic model used for making control calculations. However, these differences have to be inside a predefined range of uncertainties. Several methods can be used to make robust control. Some of them are: adaptive control with a robust observer,  $H_2$  and  $H_\infty$ , parameter estimation, neural networks and fuzzy control [8].

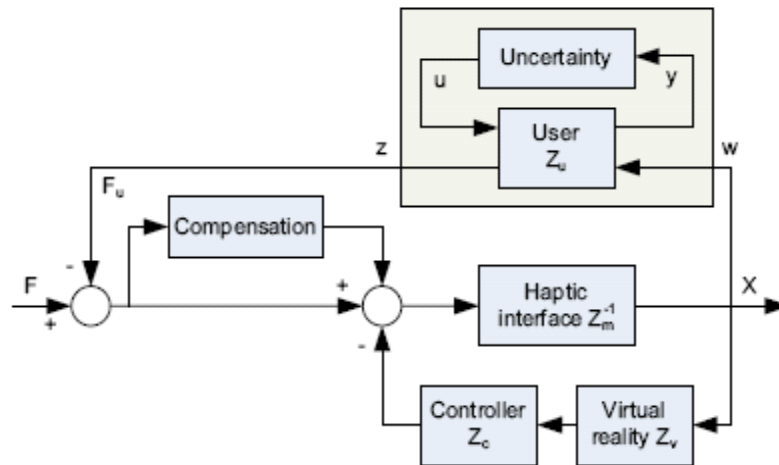

Figure 1.12 Robust control schemes [8].

### ❖ Optimal control

To control a dynamic system and to determine the best control strategy for the system we need to specify a payoff criterion. This way, the optimal control aim is to maximize the payoff and minimize the cost. It is important to remark that the optimal control has a close relation with the dynamic model.

## 1.3 Conclusion

Impedance controlled device don't necessarily require force measurements, frequently simple open loop control are used. The impedance control devices are usually lightweight, highly backdrivable, backlash free, and renders low mass. Most of the impedance control devices are cable driven. Since this is a good choice to render low impedances. But there performance reduces when higher forces are required in order to simulate heavy mass and stiff contacts. Adding complex end effectors (mass or sensor) is also a problem. Also the force feedback impedance controlled device, may cause stability problem if compensation for dynamics and friction is not correct, may also amplify noise.

On the other hand admittance control devices are capable of simulating stiff environment and also capable to eliminate friction, giving an isotropic and a very free feel motion of end-effector. The higher gain in the inner control loop closed on motion; eliminate device non-linear dynamics as for instance friction. Therefore they are very suitable for stiff contacts and larger workspaces and nonlinear dynamics of device. However, they are often not capable of rendering very low mass and low impedances, which causes reduction in close-loop bandwidth of the force-feedback. Also in motion controlled haptic devices it is desired to follow the required motion trajectory while eliminating frictional forces. During the interaction with objects in virtual environment the motion error induced by contact forces is tried to be compensated by high-gains motion feedback control, resulting large interaction forces. Thus, contact with very stiff rigid bodies may result very lager

interaction forces that may be cause instability, damage of manipulator or object and actuator saturation.

Table 1 COMPARISON BETWEEN IMPEDANCE AND ADMITTANCE CONTROL

<b>Impedance Control</b>	<b>Admittance Control</b>
Displacement in and force out	Force in and displacement out.
Lightweight, backlash free, stick slip free and renders low mass.	It is not capable of rendering very low mass, meaning inertia will always be felt.
The performance lacks in the region of higher forces, high mass and high stiffness.	Capable of rendering very high stiffness, near to zero friction and zero end-effector weight.

## 1.4 Stability problem of haptic interfaces

In the previous section it has been discussed that the accuracy of the haptic feedback improves with an increase of the controller gains. However, in practical the control gains cannot be increased beyond some limit causing the stability problem. The main possible sources for stability problems of haptic devices are:

- stiction and Coulomb friction
- actuator saturation and bandwidth
- sensor noise
- sampling rate of time discrete implementation
- flexibility of robot joints and links
- sensor dynamics
- virtual environment dynamics
- human arm dynamics
- operator's dynamic force/motion input

## 1.5 Dynamic model of Haptic interface

The dynamic model of haptic device when the user interact with the device can be represent as

$$f = M(x)\ddot{x} + V(x)\dot{x} + G(x) + F_u$$

Where M is the mass matrix, V is the centrifugal and corelis forces and G is the gravitational force.  $F_u$  is the user contact force while x represents task space coordinates. The torque that applied to the motor (joint) can be obtained by Jacobian matrix as

$$\tau = J^T f$$

The user contact force can be controlled by the input force u, if we compensate for the dynamics of the haptic interface properly.

$$\frac{X(s)}{F(s)} = \frac{1}{[Z_u + Z_e]}$$

## User contact impedance

In order to feel the realistic contact forces and torque from the virtual environment, it is needed to include the user contact impedance in the impedance control structure of the haptic device. The contact impedance model between the user and the haptic device can be obtain by spring model as

$$F_u = b\dot{x} + k\Delta x$$

Where  $b$  and  $k$  represents the user damping and stiffness coefficients, respectively and  $\dot{x}$  is the velocity of the tool center point(TCP) while  $\Delta x$  is change in position.

## 1.6 Implementation of haptic control structure for 1-DoF haptic device.

To analyze the performance of the above haptic control structures and to investigate stability issues a 1-DoF haptic device has been used. This device consists of a dc motor coupled to the linear actuator that can provide translation motion only in one direction shown in figure (1.13). A ball screw mechanism was used to convert angular motion to linear motion. A force sensor is mounted to TCP to measure the forces.

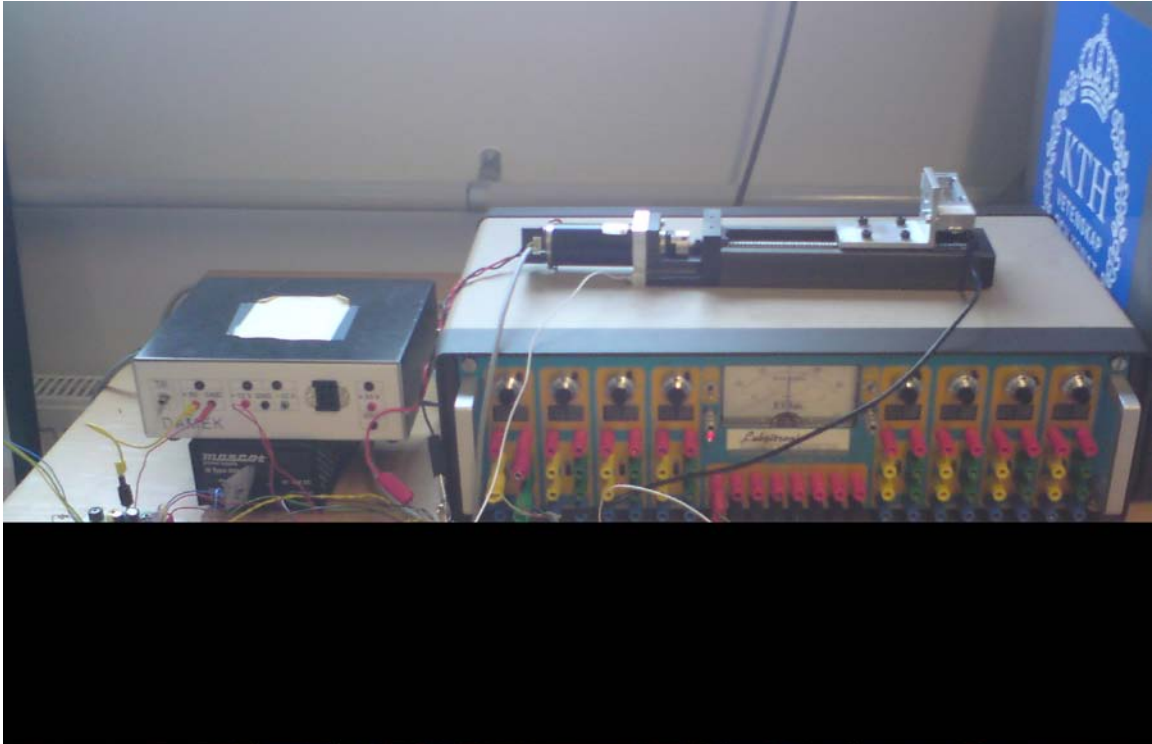



Figure 1.13 Hardware setup for 1-DoF haptic device

Further more the device is interfaced with real time workshop (Simulink) through dSpace board (Rti1104). The collision detection is implemented in Simulink through simple spring model to get the contact forces from manipulated objects.

- *Open loop impedance control*

In the first case in open loop impedance control structure was implemented for 1-DoF haptic device as shown in figure.

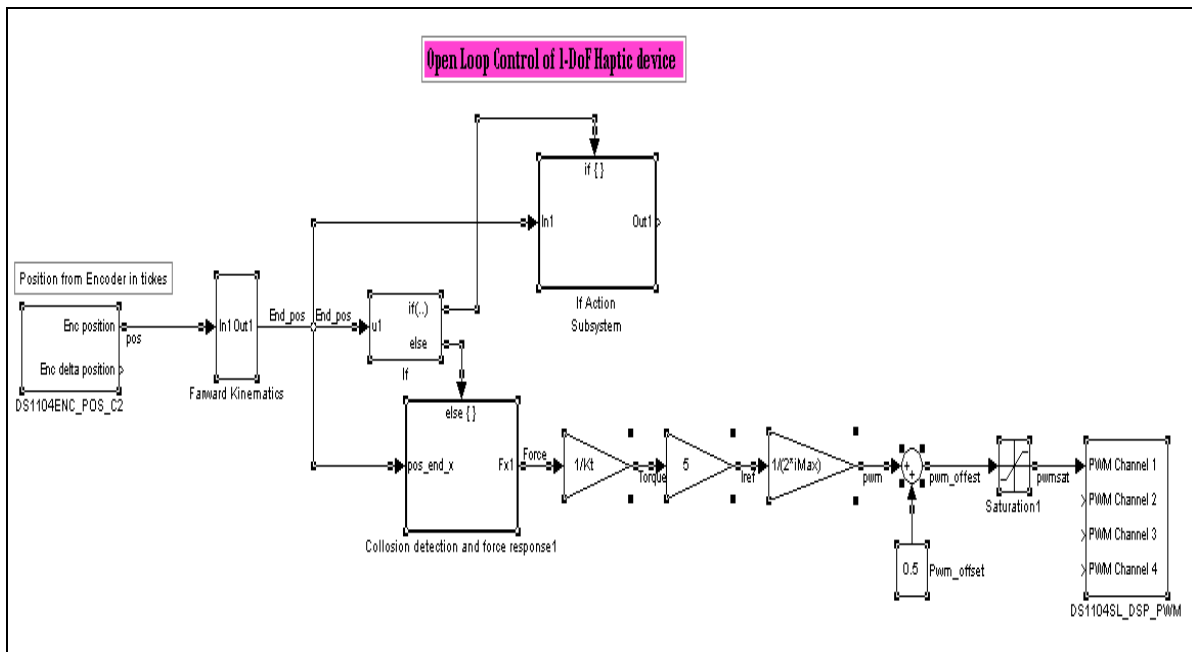

Figure 1.14 open loop control structure of 1-Dof haptic device in simulink[8].

In the above structure we read the encoder value and then calculate the TCP position using forward kinematics. The TCP position is sent to collision detection algorithm. If there is collision it returns force. The force is converted to the torque and then reference current ( $I_{ref}$ ). Further more the reference current ( $I_{ref}$ ) is converted to PWM signal (0-1) to provide the desired torque (force) to the user on TCP point. This control structure is very

simple and easy to implement, but it does not fulfil the requirements as discussed in section 1.1. The device is stable and provides the required stiff contact feedback force with slow motion of TCP. With fast motion the device not remain stable at all and also the motion does not feel free in the free space. Furthermore there is an anti windup effect and friction that feels more, this effect the realistic contact forces from manipulated objects.

- *Open loop impedance control with current feedback for actuator*

To improve the performance of the open loop impedance control structure a PI controller for current feedback was implemented. The real current from the motor was measured through voltage drop in the resistor, and then a filter was implemented to reduce the noise level in the measured current signal as shown in figure 1.14. Now the device is stable with slow and as well as fast motion but still we have the anti windup and friction affect that effect the performance of the device.

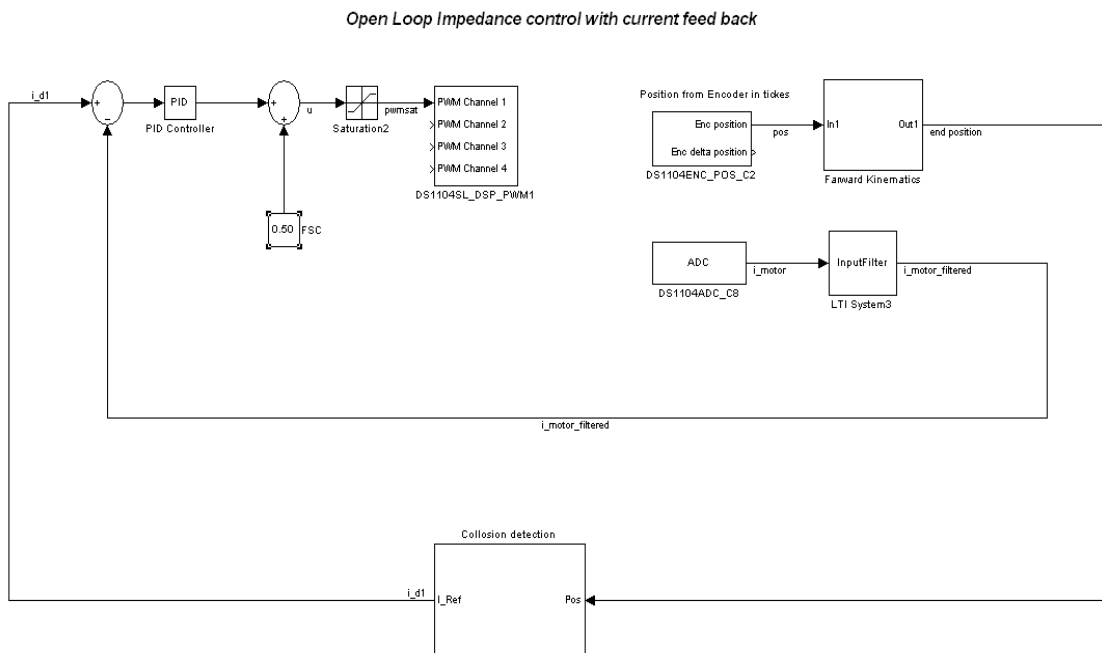

Figure 1.14 Open loop impedance control structure with current feedback.

- *Close loop impedance control with friction and back emf compensation*

In this structure an effort was made to compensate for back-emf and friction of the model as shown in figure 1.15. The performance of the device drastically improves. Now it feels free in the free space and stiff while within interaction with objects. It also remains stable irrespective of fast and slow motion. The friction model that is used is shown in figure 1.16



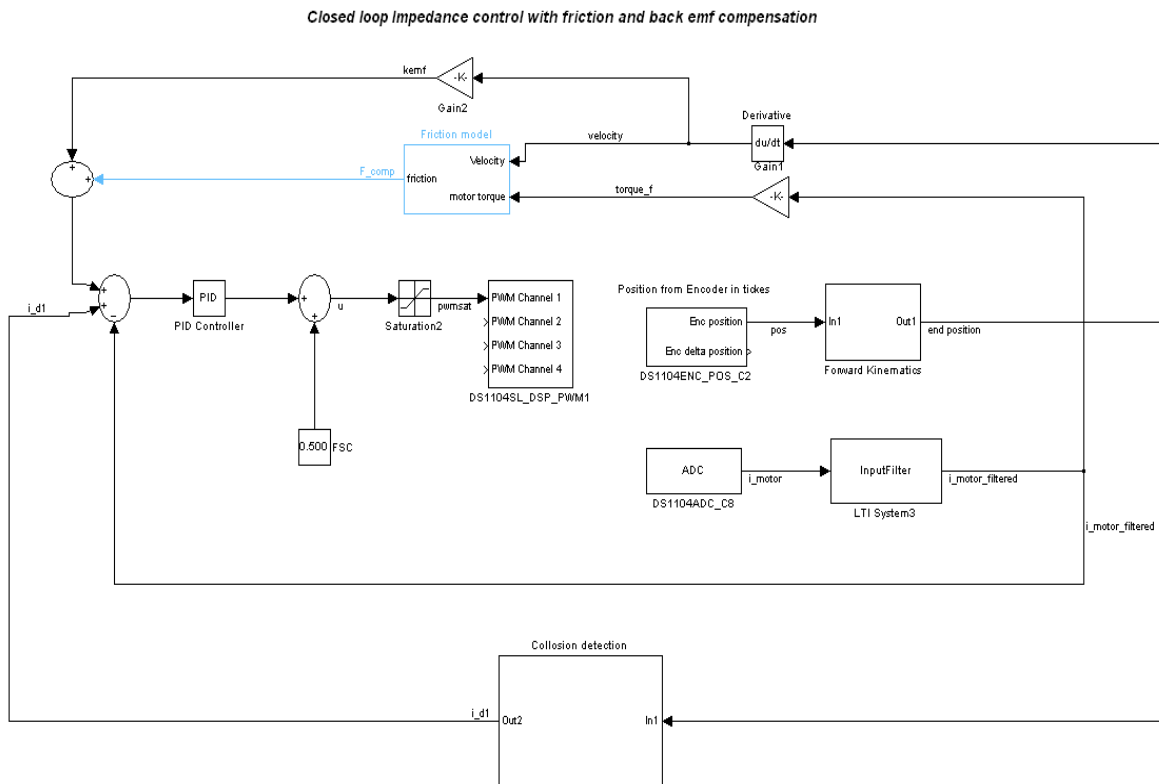

Figure 1.15 Closed loop impedance control structure with friction and back-emf compensation.

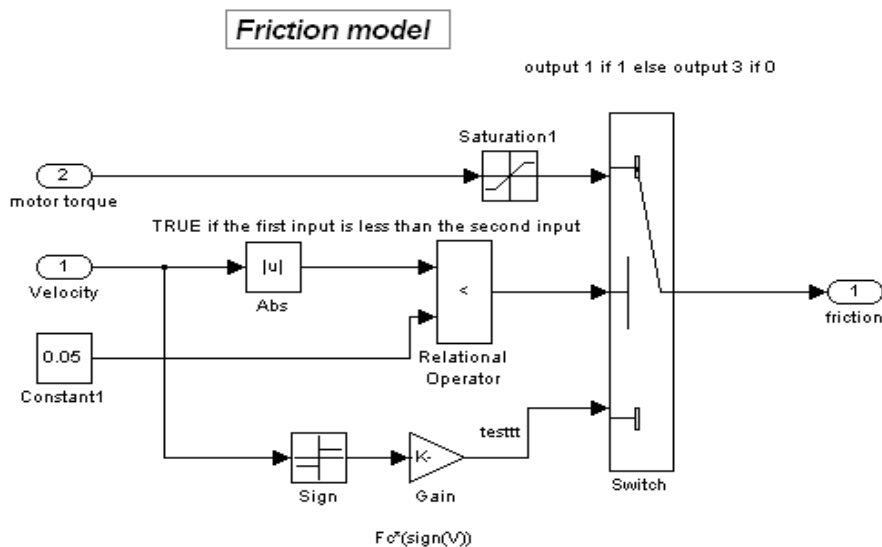

Figure 1.16 Friction model.

- *Close loop impedance control with friction and back emf and user contact force compensation*

In the above control structures there is an effect of force due to user contact. It's needed to be compensated for user contact forces in order to feel the real feedback force from manipulated objects. A simple spring model with damping was used to compensate for this shown in figure 1.18. The performance is more improved with all these compensation and the device is stable even though with uncertainty from user, how he applying the force.

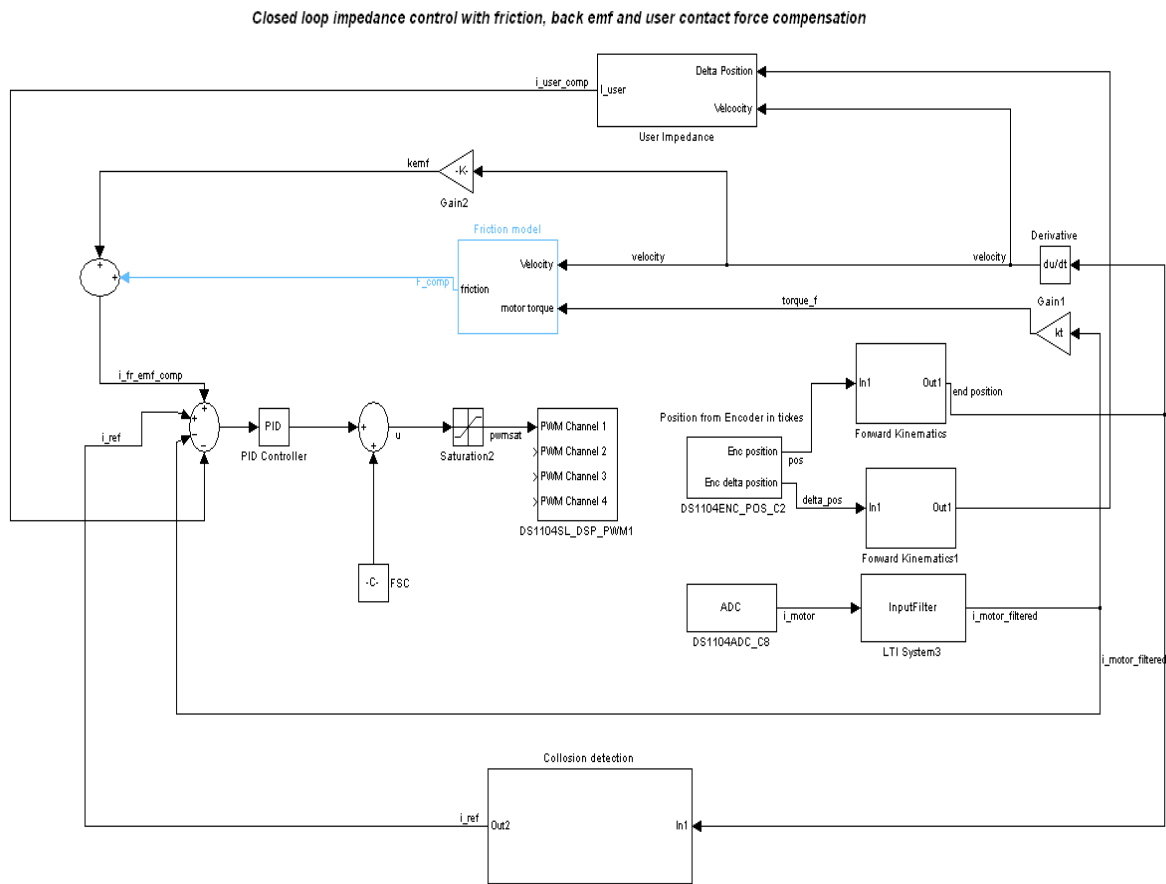

Figure 1.17 closed feedback control structure with user contact force compensation

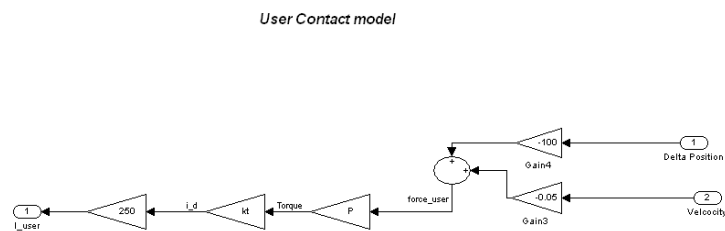
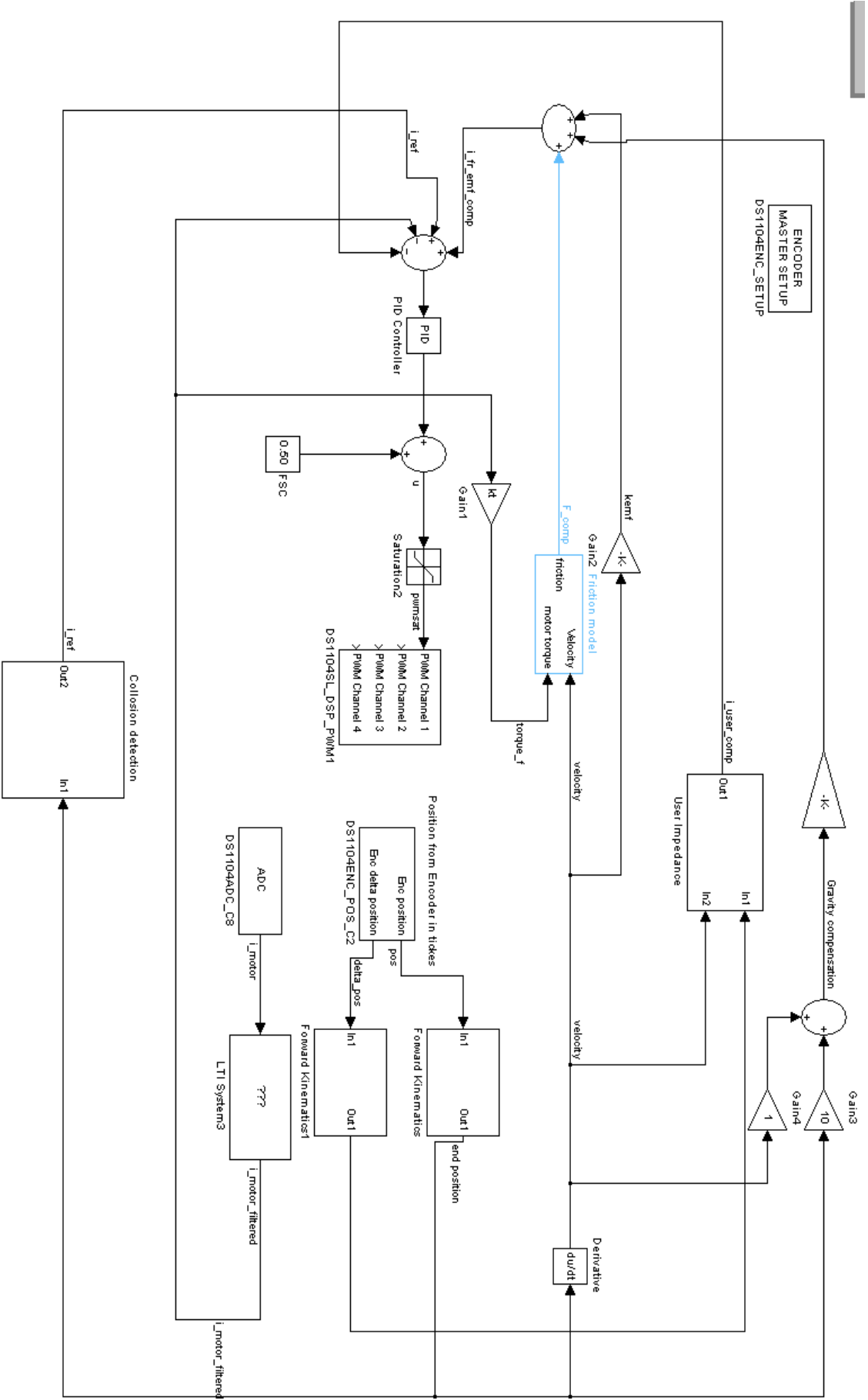

Figure 1.18 user contact model

- *Compensation for gravity term*

In the next figure we compensation for gravity term.



- *Admittance control*

As in the admittance control architecture the control law is force in and position out-mean it control the position of the haptic interface. This scheme typically will suit for device with high dynamics and for stiff contacts. In this structure the position is sensed and used to control the device (opposite to the impedance). The force cell is used to measure the forces applied on TCP and send to collision detection block. When there is no collision (free space motion), no force from virtual environment and so the contact forces zero gives zero reference signal to the control. While when the collision occurs a spring model is used to calculate the change in position from force signal as

$$\Delta X = -\frac{Fs}{K}$$

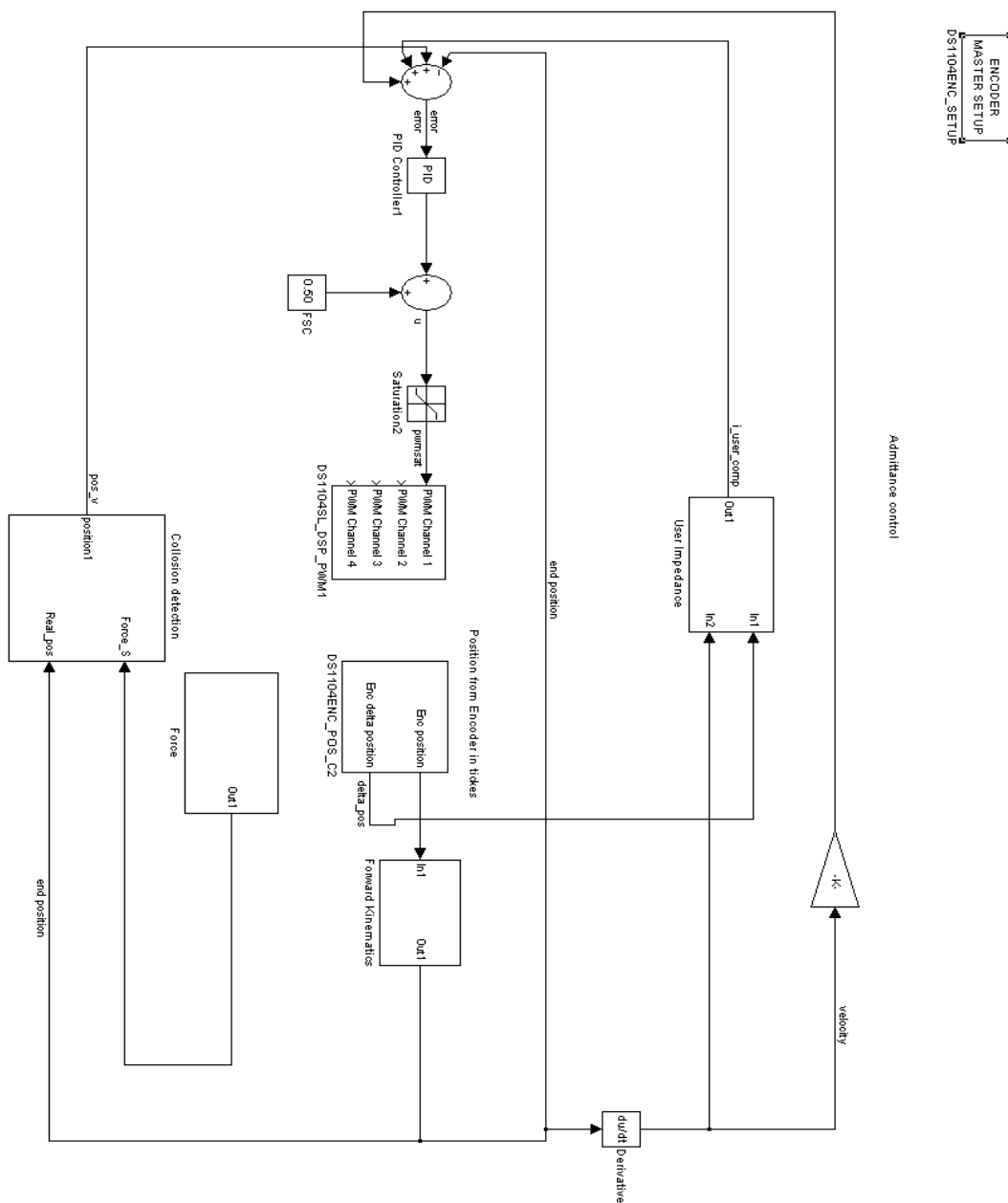

The change in position is actually a reference signal and sent to the controller to provide the forces or feeling of contacts to the users. This structure is very useful in case of stiff contacts. Also a compensation for the user model and device dynamics is made to feel realistic contact forces from virtual environment.

## References

- [1] T. Massie and J. Salisbury, "The PHANTOM haptic interface: A device for probing virtual objects," in Proceedings of the ASME Winter Annual Meeting, Symposium on Haptic Interfaces for Virtual Environment and Teleoperator Systems.
- [2] Magnus G. Eriksson, Mark Dixon and Jan Wikander "A Haptic VR Milling Surgery Simulator Using High-Resolution CT Data" 14<sup>th</sup> MMVR conference in Los Angeles, USA, January, 2006.
- [3] R. Q. van-der-Linde and P. Lammertse and E. Frederiksen and B. Ruiters "The HapticMaster, a new high-performance haptic interface". EuroHaptics Conference. 2005.
- [4] M. Ueberle and N. Mock, VISHARD10. "A Novel Hyper-Redundant Haptic Interface." In Proc. 12th Int. Symp. Haptic Interfaces Virtual Environ. Teleoperator Syst. 2004. pp. 58-65.
- [5] Park.H and J.M.Lee "Adaptive impedance control of a haptic interface" Mechatronics 14 (2004) 237-253
- [6] C. Carignan and K. Cleary, "Closed-loop force control for haptic simulation of virtual environments," Haptics-e, vol. 1, no. 2, 2000, <http://www.haptics-e.org>.
- [7] Hogan N., 'Impedance Control "An Approach to Manipulation: Part I-Theory, Part II-Implementation, Part III-Applications'". Journal of Dynamic Systems, Measurement and Control. (1985).
- [8] Mildred J. Puerto, Emilio S´anchez and Jorge Juan Gil "control algorithm for haptic interaction and modifying the dynamical behavior of the interface", Proceedings of ENACTIVE05 2nd International Conference on Enactive Interfaces Genoa, Italy, November 17th-18th, 2005
- [9] Mildred J. Puerto, Emilio S´anchez and Jorge Juan Gil "Control strategies applied to kinesthetic haptic devices" Applied Mechanics Department, CEIT, E-20018 San Sebastian, Spain
- [10] J. Maples and J. Becker, "Experiments in force control of robotic manipulators," in Proceedings of the 1986 IEEE International Conference on Robotics & Automation, pp. 695-702.
- [11] H. Maass, B.A. Chantier, H. K. Cakmak and U. G. Kühnapfel "How to add a force feedback to surgery simulator" IS4TM 2003, LNCS 2673, pp. 165-174, 2003. Springer-Verlag Berlin Heidelberg 2003
- [12] Burdea, G. "Force and Touch Feedback for Virtual Reality". John Wiley and Sons (1996), ISBN: 0-471-02141-5
- [13] E. L. Faulring, J. E. Colgate and M. A. Peshkin. "The Cobot Hand Controller: Design, Control and Performance of a Novel Haptic Display". The International Journal of Robotics Research. 2006. vol. 25. pp. 1099-1110.
- [14] Hogan N., 'Impedance Control "An Approach to Manipulation: Part I-Theory, Part II-Implementation, Part III-Applications'". Journal of Dynamic Systems, Measurement and Control. (1985).
- [15]
- [16] Andersson, K., Khan, S. "Investigation of parallel kinematic mechanism structures for haptic devices", presented at 2<sup>nd</sup> Nordic Conference on Product Lifecycle Management - NordPLM'09, Gothenburg January 2009.

```

%*****
%*****
% Modeling of 1-DoF haptic device driven by Dc motor and having load as
link .
% P controller with low pass filter for current
%*****
%*****
%% Input parameter or specification identified
clear all
clc
s=tf('s')
n=1; %gear ratio
P=0.009/(2*pi) %Pitch m/rad.
kt=52.5*1e-3 %torque constant Nm/A
ke=0.0524 %rad/V
dm=0.03 %damping Nm/s at motor side
Imax=20.3 %max current ampere
Jr=7.2*1e-6; %inertia of the motor rotor Kg*m2
Jc=7.2*1e-6; %inertia of the coupling Kg*m2
Js=800*1e-6; %inertia of the ball screw Kg*m2
M=0.511 %mass load+nut+screws
Jtot=M*P^2+(Js+Jr+Jc) %total inertia Kg*m2
r=2.07 %Resistance ohm
L=0.620*1e-3 %inductance (H)
Fc=0.005 %static friction N
Ts=0.001;
Umax=15.4; %max voltage to motor
iMax = 0.1;
Ki = 1;
xmax=25; % virtual wall
xmin=-25; % virtual wall
kspring=1000000; %Spring constant for collosion model
%% Model of the motor between voltage and output current

% B=1/L
% A=s+(r/L)
% omegal=300;
% omega2=250;
% A0=s+omegal
% Am=s+omega2;
% s0 =(omegal*omega2*L);
% s1 =(-r+omegal*L+omega2*L);
% S=s1*s+s0
% R=s
% t0=1/dcgain(B/Am)
% T=A0*t0
% Gc=minreal((B*T)/(A*R+B*S))
% figure(1) % bode diagram of Closed loop
system
% margin(Gc)
% figure(2) % Step diagram of Closed loop
system
% step(Gc);
% stepinfo(Gc)
%% filter for the measure current

```

```

InputFilter=(1/(s/37+1))

%% filter for the measure force

InputFilter_force=(1/(s/10+1))
%% PI current controller with filter

% zeta=0.07;
% omegal=1;
% omega2=6;
%
%
% Am = s+omegal;
% Ao = s^2+2*zeta*omega2+omega2^2;
%
% r0 = (omegal*L-r)/L;
% s0 = 2*omegal*omega2*L*zeta+omegal*omega2^2*L;
% s1 = (2*zeta*omega2*L^2+omega2^2*L^2-r*omegal*L+r^2)/L;
% S=s1*s+s0
% R=s*(s+r0)
% t0=1/dcgain(B/Am)
% T=A0*t0
% Gc=minreal((B*T)/(A*R+B*S))
% figure(3) % bode diagram of Closed loop
system
% margin(Gc)
% figure(4) % Step diagram of Closed loop
system
% step(Gc);
% stepinfo(Gc)
% %%

```

>

## Chapter 1 PI controller for motor to control current

```
> restart; B:=1/L;
```

$$B := \frac{1}{L}$$

```
> A:=(s+r/L);
```

$$A := s + \frac{r}{L}$$

```
> S:=s1*s+s0; R:=s; Acl:=collect((A*R+B*S),s);
```

$$S := s1 s + s0$$

$$R := s$$

$$Acl := s^2 + \left( \frac{r}{L} + \frac{s1}{L} \right) s + \frac{s0}{L}$$

```
> Am:=(s+omega1);
```

$$Am := s + \omega1$$

```
> Ao:=(s+omega2);
```

$$Ao := s + \omega2$$

```
> pd:=collect(Am*Ao,s);
```

$$pd := s^2 + (\omega1 + \omega2) s + \omega1 \omega2$$

```
solve({coeff(pd,s,1)=coeff(Acl,s,1),coeff(pd,s,0)=coeff(Acl,s,0)},{s1,s0});
```

$$\{s0 = \omega1 \omega2 L, s1 = -r + \omega1 L + \omega2 L\}$$



## Chapter 2 Pi controler for motor with low pass filter to control current

```
> S:=s1*s+s0; R:=s*(s+r0);Acl:=collect((A*R+B*S),s);
```

$$S := sI s + s0$$

$$R := s (s + r0)$$

$$Acl := s^3 + \left( \frac{r}{L} + r0 \right) s^2 + \left( \frac{r r0}{L} + \frac{sI}{L} \right) s + \frac{s0}{L}$$

```
> Am:=(s+omega1);
```

$$Am := s + \omega l$$

```
> Ao:=(s^2+2*zeta*omega2+omega2^2);
```

$$Ao := s^2 + 2 \zeta \omega 2 + \omega 2^2$$

```
> pd:=collect(Am*Ao,s);
```

$$pd := s^3 + \omega l s^2 + (2 \zeta \omega 2 + \omega 2^2) s + \omega l (2 \zeta \omega 2 + \omega 2^2)$$

```
>
```

```
solve({coeff(pd,s,2)=coeff(Acl,s,2),coeff(pd,s,1)=coeff(Acl,s,1),coeff(pd,s,0)=coeff(Acl,s,0)},{s1,s0,r0});
```

$$\left\{ r0 = \frac{\omega l L - r}{L}, s0 = 2 \omega l \omega 2 L \zeta + \omega l \omega 2^2 L, s1 = \frac{2 \zeta \omega 2 L^2 + \omega 2^2 L^2 - r \omega l L + r^2}{L} \right\}$$



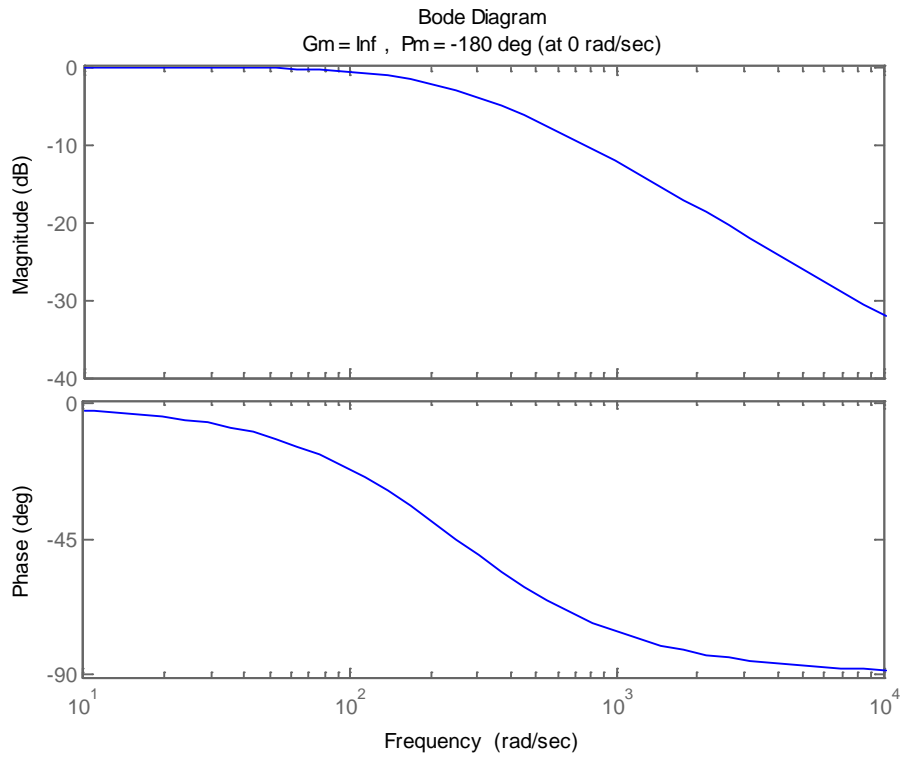
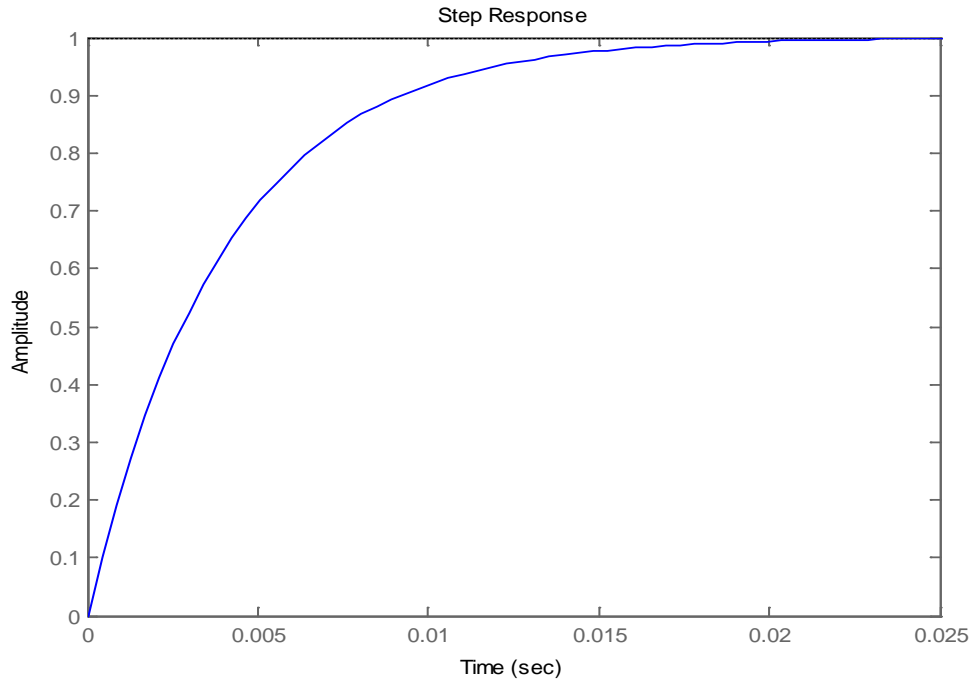

Step response and bode diagram of the closed loop system for current control.